



Product info sheet no. C 2.4
Humidity/-temperature sensor
Meteorological design

Description

Mela®-humidity/-temperature sensors in the PC-ME series with a fixed connecting cable (5 m), PK-ME series without cable or RC-ME series with a robust aluminium connecting head and terminal screws are compact sensors in a rod-type design. They have a high degree of accuracy and have been specially developed for meteorological applications. All the sensors in the series are fitted with the **ZE20**-type membrane filter.

We recommend that you use the version with the the **ZE 21/ZE22** ¹⁾type sintered high-grade steel filter (filter programme see product info sheet no. F 5.1) at high wind speeds or if the sensor is exposed to salt mist, sand or dust (near the sea, industrial estates etc.). The advantage of the .../9 series is the improved temperature dynamics, in particular at low air speeds.

1) In the series .../9 it is not possible to exchange the protective plastic basket ZE16 with other filters.

Type versions

Measured variable	Analogue output	with filter	with integrated
		ZE 20 or ZE21 Pt-100 platinum chip	PTFE filter protection ZE 16, Pt-100 glass
F rel. humidity	0...10 V	FP* 2/x - ME	FP* 2/9 - ME
	0...1 V	FP* 1/x - ME	FP* 1/9 - ME
C r.h. + temp.	0...10 V, Pt 100	CP* 2/x - ME	CP* 2/9 - ME
	0...1 V, Pt 100	CP* 1/x - ME	CP* 1/9 - ME
K r.h. + temp.	2 x 0...10 V	KP* 2/x - ME	KP* 2/9 - ME
	2 x 0...1 V	KP* 1/x - ME	KP* 1/9 - ME
T temperature	Pt 100	TP* 5/x - ME	TP* 5/9 - ME
	0...10 V	TP* 2/x - ME	TP* 2/9 - ME
	0...1 V	TP* 1/x - ME	TP* 1/9 - ME
weight		approx. 310g	approx. 300g

Technical data



Humidity

measuring range 0...100% rh
accuracy (mr 5...95% rh at 10...40°C) ±2% rh
temperature influence <10°C, >40°C <0.1%/K additional

Temperature

measuring element (ref. DIN IEC 751) Pt 100 1/3 DIN
measuring range -30...+70°C
accuracy
output: 0...1V (-27...70°C) ±0.2 K
0...10V (-29...70°C) ±0.2 K
4...20 mA (RC) ±0.3 K
temperature influence <10°C, >40°C ±0.007 K/K additional

Other Data

ambient temperature -40...+80°C
degree of protection sensor/electronic IP 30/IP 65
operating voltage
output voltage 0...10V 15...30 V DC
output voltage 0...1V 6...30 V DC
output current 12...30 V DC
min. load resistance 0...10V/ 0...1V ≥ 10 kΩ/≥ 2 kΩ
load (current output) acc. diagramm
power consumption
0...10 V, 2 x 0...1V <5mA
0...1V <1mA
minimum air speed (across the sensor)
output: 0...10V, 2x 0...1V ≥ 0.5 m/s
4...20mA, 2x 0...10V ≥ 1.5 m/s
2x 4...20 mA ≥ 1.5 m/s
self-heating coefficient Pt100 (v=2 m/s in air) 0.2 K/mW
electromagnetic compatibility ref. EN 61326-2-3

„subject to technical modifications“

Special versions available on request

Sensor with 5 m cable * = C
Sensor without cable * = K

Measured variable	Analogue output	with filter	with integrated
		ZE 20 or ZE21 Pt-100 platinum chip	PTFE filter protection ZE 16, Pt-100 glass
F rel. humidity	4...20 mA	FRC 3/x - ME	FRC 3/9 - ME
	0...10 V	FRC 2/x - ME	FRC 2/9 - ME
	0...1 V	FRC 1/x - ME	FRC 1/9 - ME
C r.h. + temp.	4...20mA, Pt 100	CRC 3/x - ME	CRC 3/9 - ME
	0...10 V, Pt 100	CRC 2/x - ME	CRC 2/9 - ME
	0...1 V, Pt 100	CRC 1/x - ME	CRC 1/9 - ME
K r.h. + temp.	2 x 4...20 mA	KRC 3/x - ME	KRC 3/9 - ME
	2 x 0...10 V	KRC 2/x - ME	KRC 2/9 - ME
	2 x 0...1 V	KRC 1/x - ME	KRC 1/9 - ME
T temperature	Pt 100	TRC 5/x - ME	TRC 5/9 - ME
	4...20 mA	TRC 3/x - ME	TRC 3/9 - ME
	0...10 V	TRC 2/x - ME	TRC 2/9 - ME
	0...1 V	TRC 1/x - ME	TRC 1/9 - ME
weight		approx. 160g	approx. 150g

/x please select the appropriate filter (refer also to data sheet F5.1)

series P*, RC

membrane filter ZE20 → x=5
sintered high-grade steel filter ZE21 → x=6

User instructions

Install the Mela®-humidity/temperature sensors in a place where characteristic climatic conditions can be measured. If it is used outdoors, it should ideally be used in a **ZA 161/1-type weather guard** (product info sheet no. F 5.1). Avoid direct sunlight.

The specified minimum air speed and - with current output - the load according to the operating voltage (diagram) should be complied with in the case of the VC series. Deviations may lead to additional measuring faults resulting of the self-heating of the sensor

The sensor can be installed in any position. However, do avoid positions where water ingress can occur. Dew formation and splashes do not damage the sensor, although corrupted measurement readings are recorded until all the moisture on the filter has dried up.

In order to maintain interference immunity in accordance with EN 61326-2-3 when it is in use, we recommend that you use a screened cable for connecting the RC series sensors, and have this fitted into the sensor's EMC conduit thread by a qualified electrician. The protective filter should

only be screwed off carefully to check functioning with a humidity standard.

It is important not to touch the highly sensitive sensor element in the process. If necessary, soiled filters can be screwed off and rinsed. When you screw them back on, bear in mind that sensors will not measure accurately again until they are completely dry. Sensors of the series .../9 can be completely and carefully cleaned in distilled water.

For mounting support we recommend the **console type 20.009** or the **attachment plate type ZA 20** (product info sheet no. F 5.1). In order to check functioning in the place of installation, we recommend that you use the **ZE 31/1-type Mela® humidity standard** (product info sheet no. F 5.2).

Please consult the **application notes for humidity sensing elements** (product info sheet no. A 1) or check with the manufacturer for further information which you need to bear in mind when using humidity sensors with capacitive sensing elements.

Load at current output

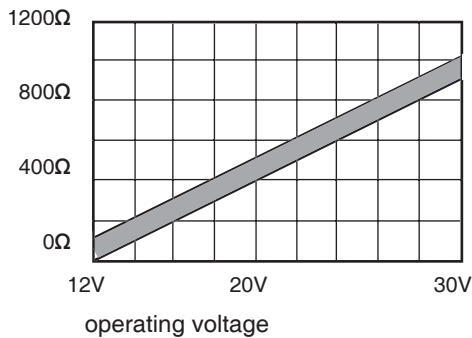

Tolerance validity range for humidity

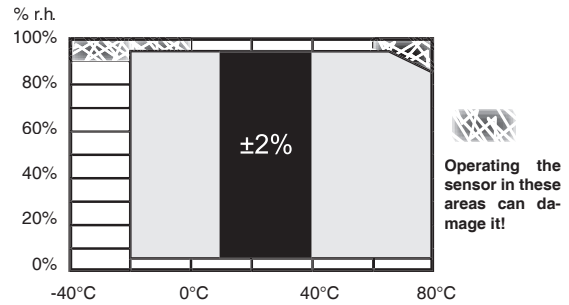

Dimensions

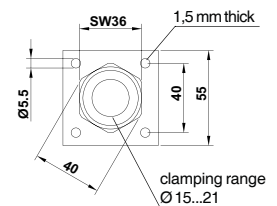
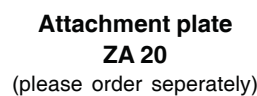
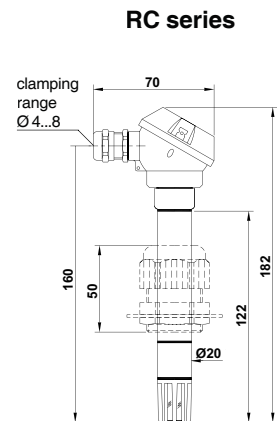
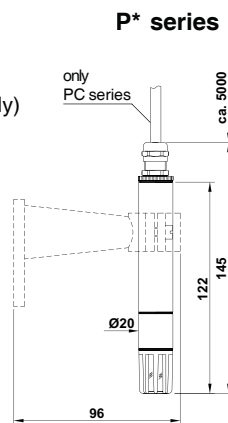
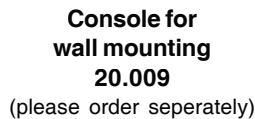
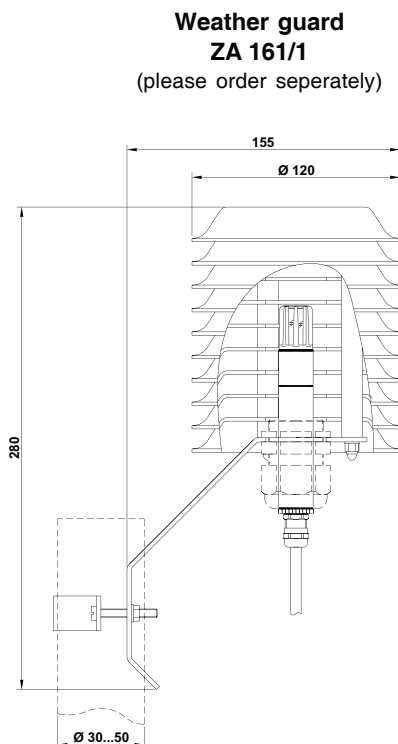

Connection diagram

Humidity/temperature sensors

Meteorological design series PC-ME

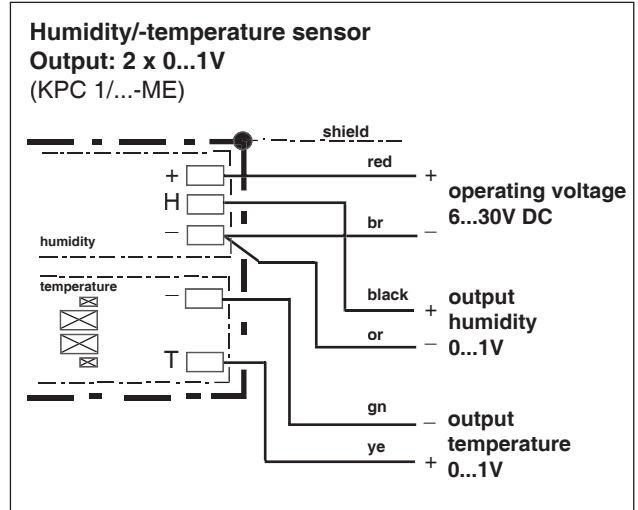
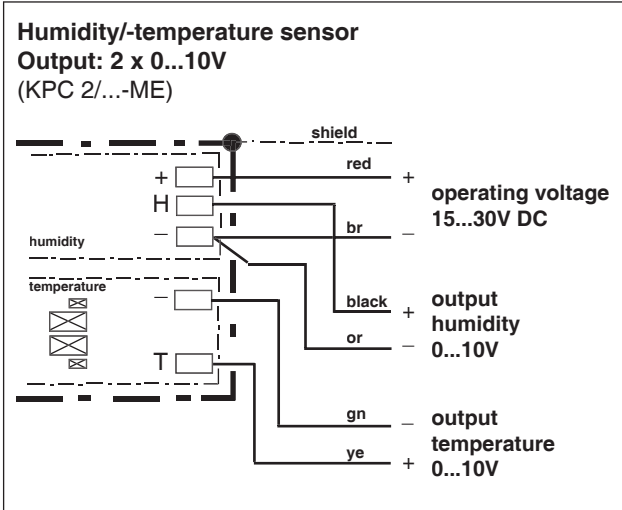

The electrical connection must only be carried out by properly qualified personnel.

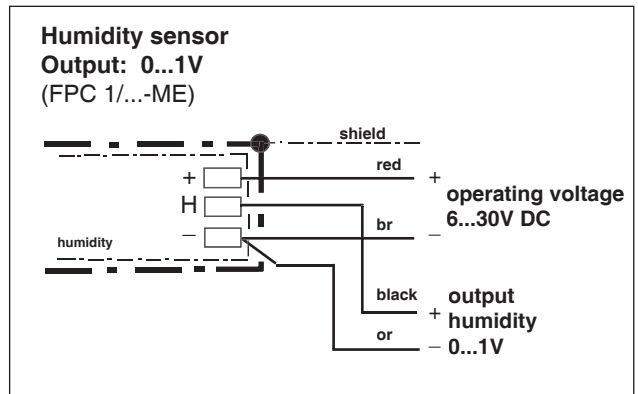
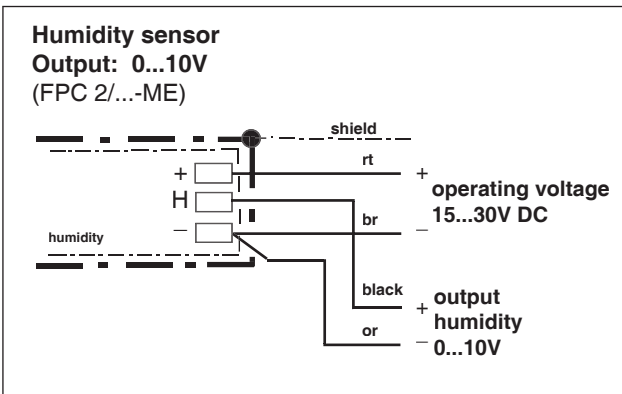
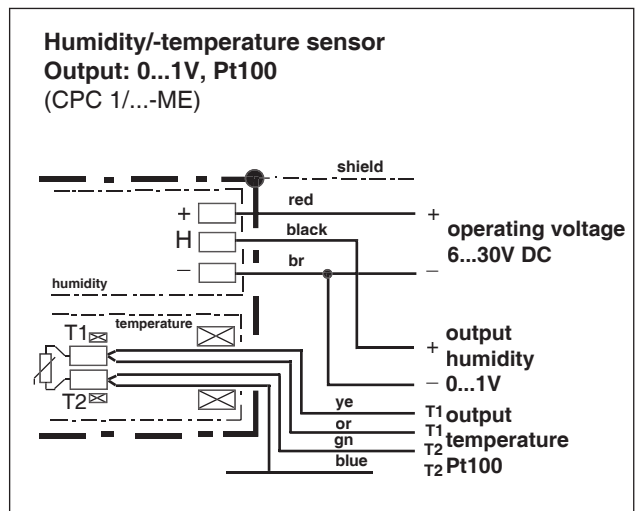
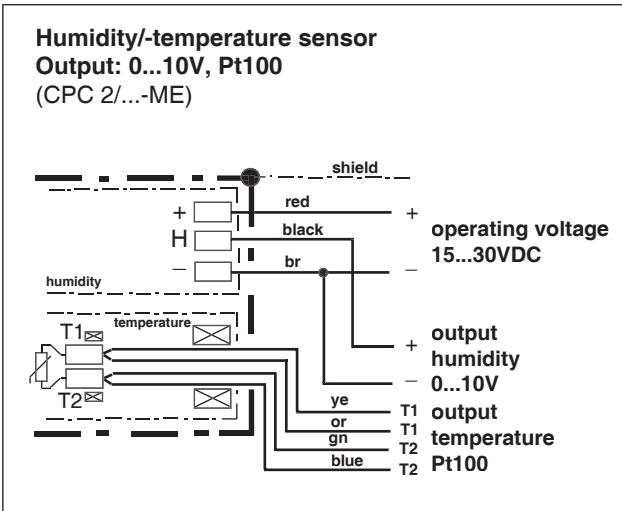

Connection diagram

Humidity/temperature sensors

Meteorological design series PC-ME

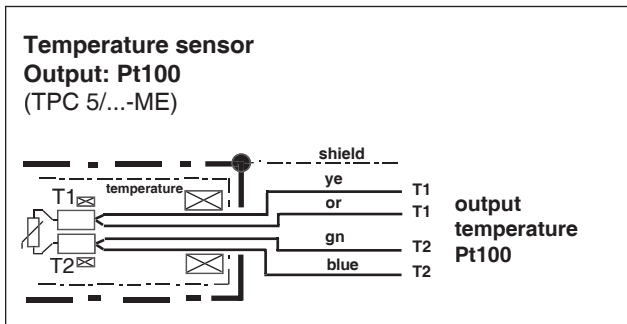
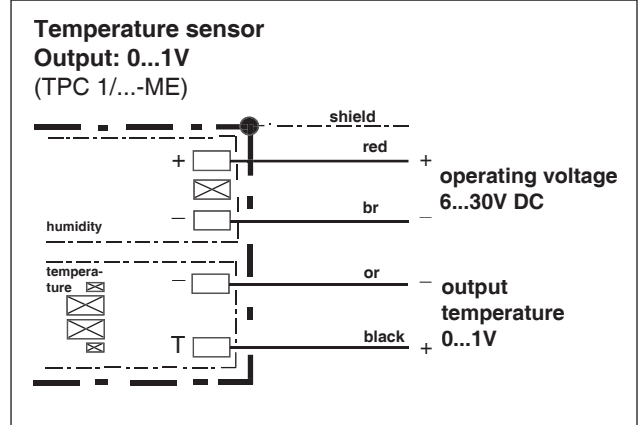
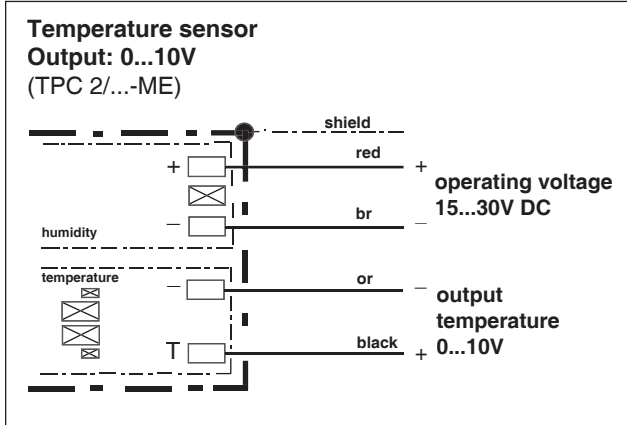

 The electrical connection must only be carried out by properly qualified personnel.

Connection diagram

Humidity-temperature sensors Meteorological design series PK-ME

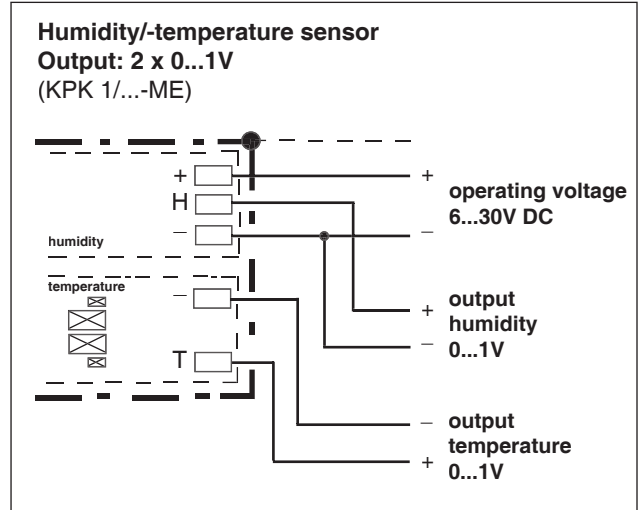
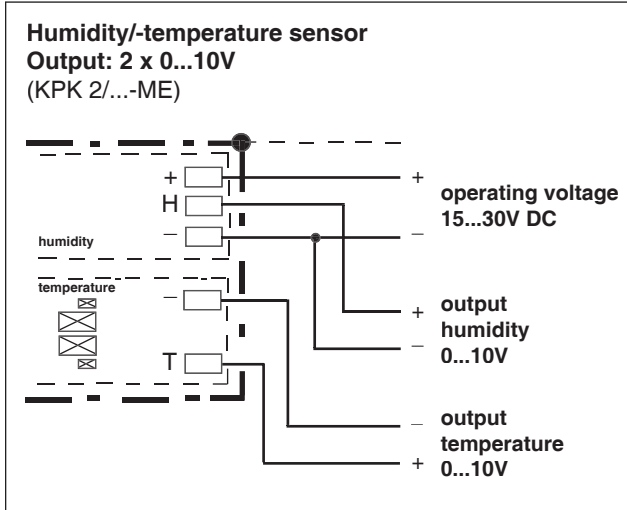

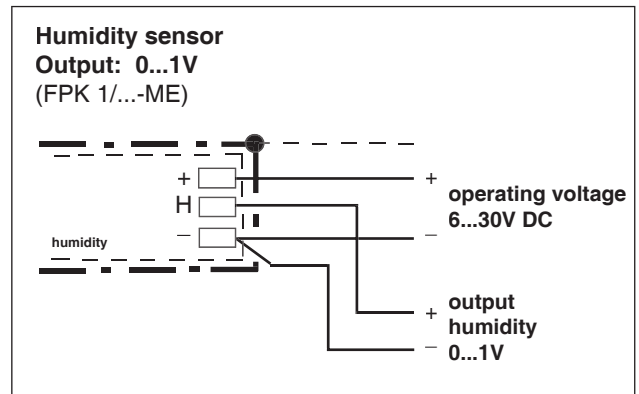
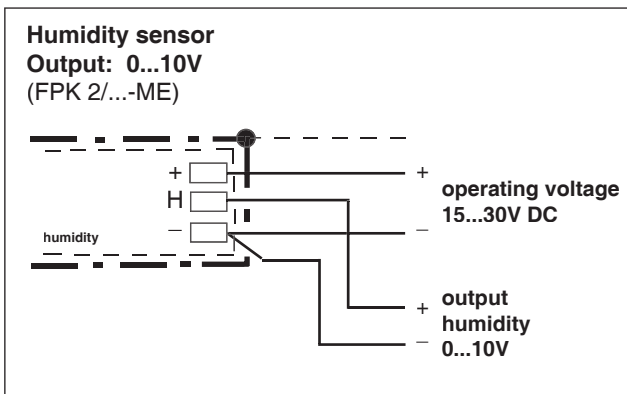
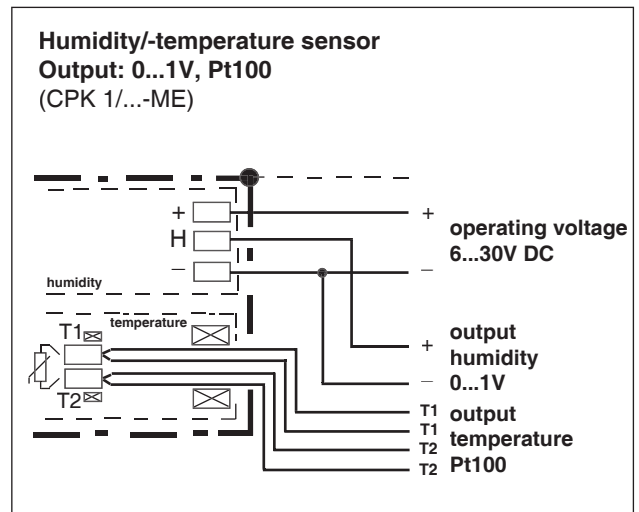
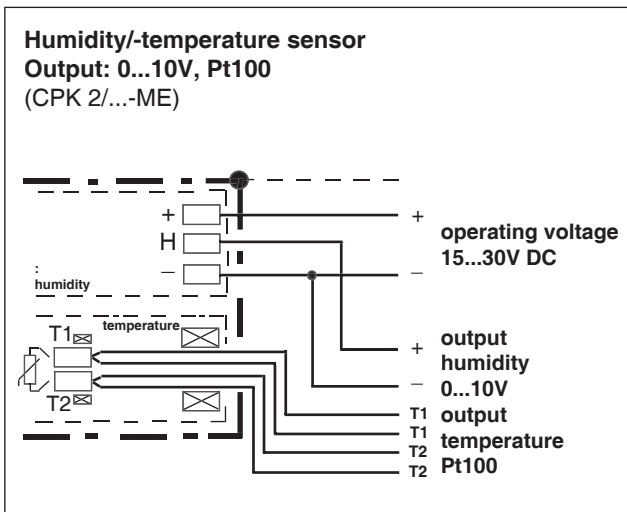

 The electrical connection must only be carried out by properly qualified personnel.

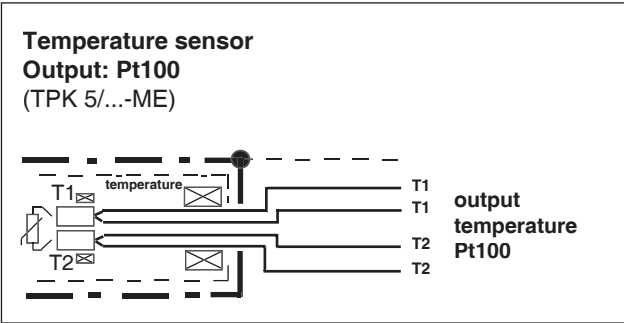
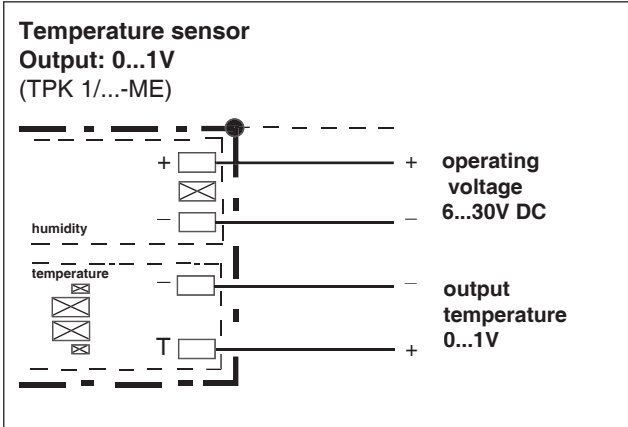
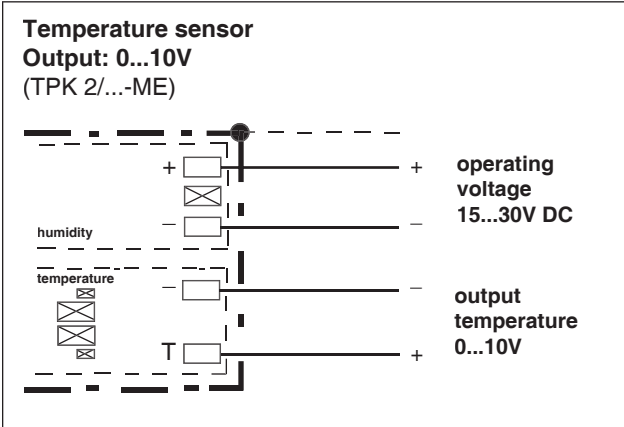

Connection diagram

Humidity/-temperature sensors Meteorological design series PK-ME



 The electrical connection must only be carried out by properly qualified personnel.

Connection diagram

Humidity/temperature sensors Meteorological design series RC-ME

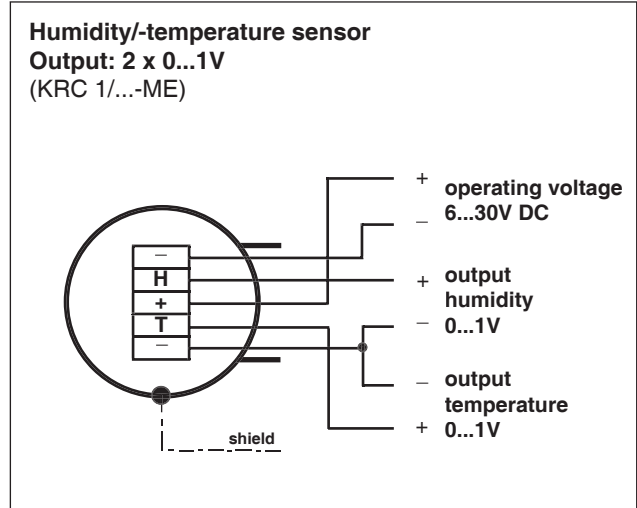
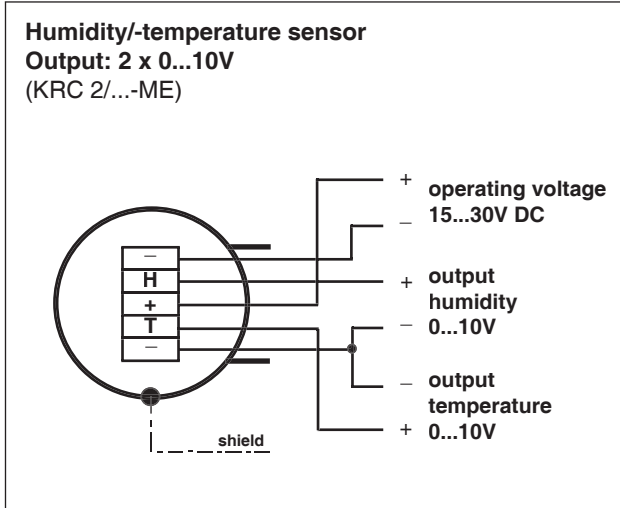

The electrical connection must only be carried out by properly qualified personnel.

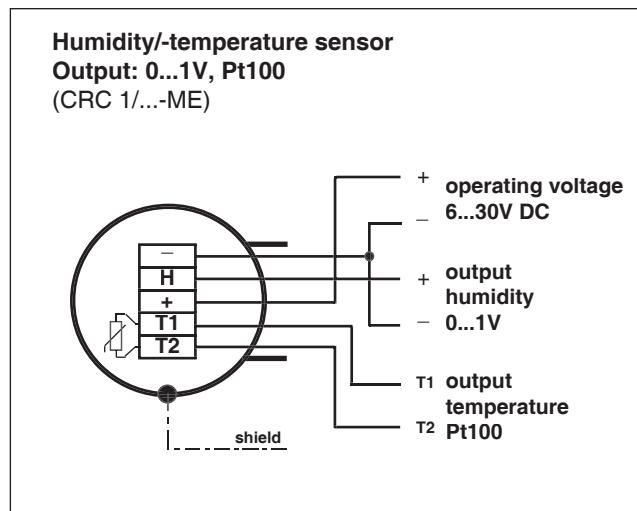
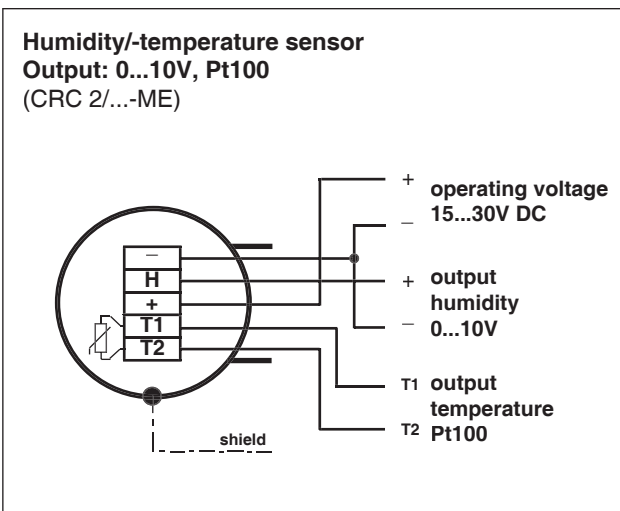
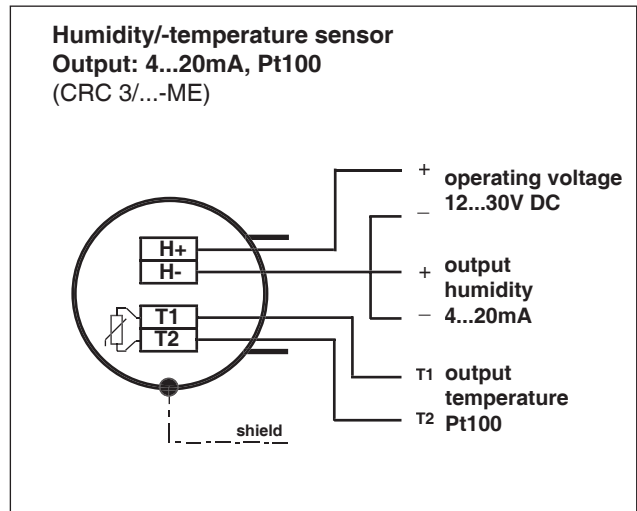
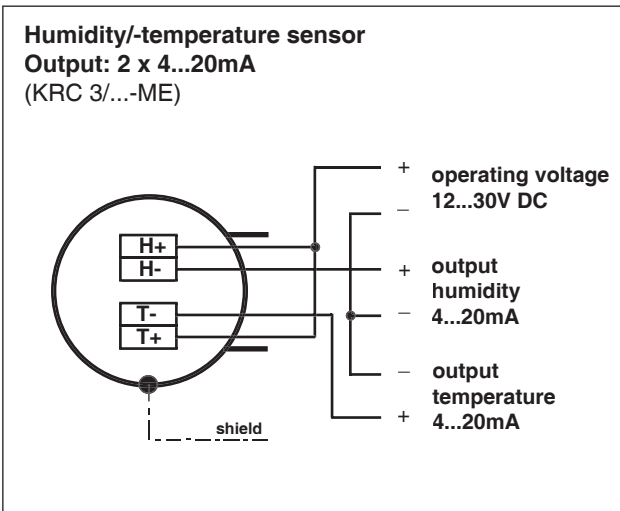

Connection diagram

Humidity/temperature sensors

Meteorological design series RC-ME

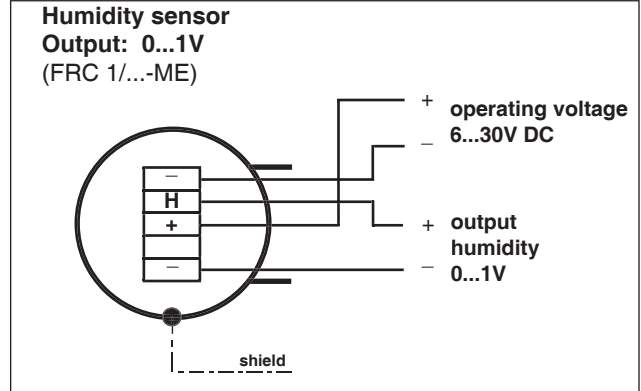
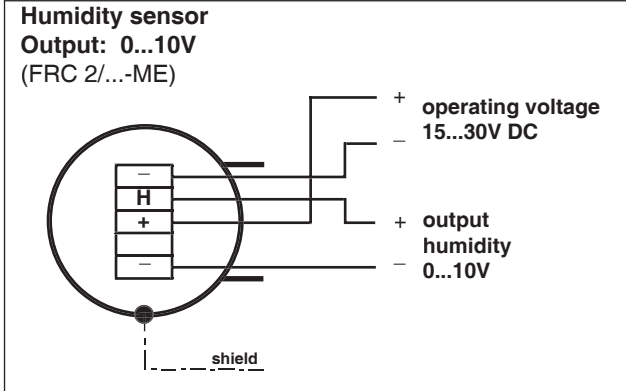

The electrical connection must only be carried out by properly qualified personnel.

